

Grease Pumps



High Pressure Heavy-Duty pump

Double acting air operated heavy-duty pumps that combine high pressure (60:1 ratio) and volume delivery. Recommended pump to deliver high viscosity greases in medium length systems that include multiple dispense points.

Pumps are available with three different suction tube lengths: 35 lb, 120 lb and 400 lb. Pumps include a height adjustable 2" bung adaptor.

3 1/4" air motor

Mechanically actuated air valve with only three moving parts and no springs. Large effective area for maximum pumping power

Efficient air exhaust

No ice forming, no stalling pump operation

Long life packings

Anti-corrosion, hardened plunger and cartridge packings assembly designed for low friction.

High quality materials

Barrel, piston and foot valve are made of hardened, precision fitted ground steel for perfect seal and longer life

Ductile iron pump body

For superior properties

Pump valve inlet

Chop-check priming valve, assists the entry of heavy and sticky grease

MARKETS SERVED

- Auto and truck dealers
- Fleet service facilities
- Mining and construction
- Lube trucks
- Railroad and mass transit
- Marine
- Industrial

FLUIDS HANDLED

- Grease up to NLGI-2

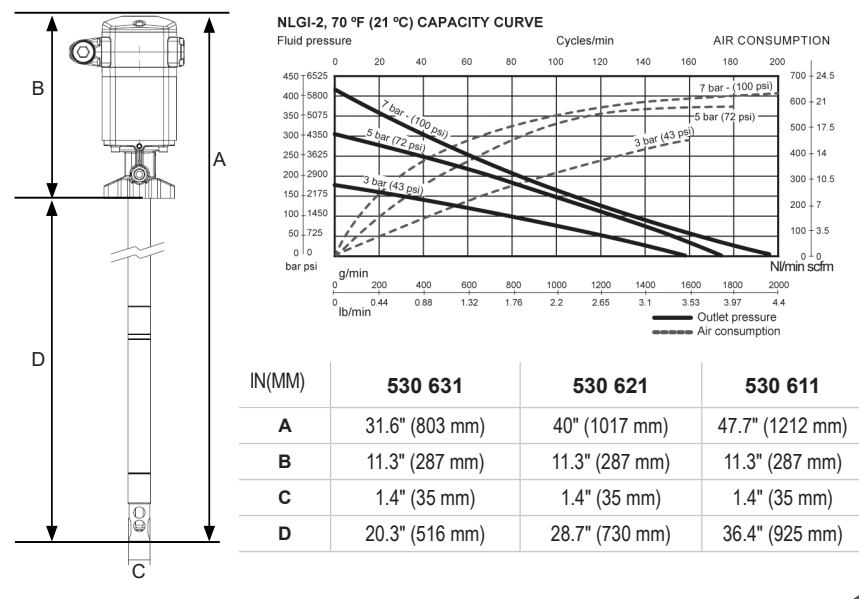

Grease Pumps

TECHNICAL SPECIFICATIONS

Pump ratio	60:1
Air pressure operating range	20 to 145 psi (1.5 to 10 bar)
Air consumption ⁽²⁾	15.9 scfm (450 NI/min)
Maximum fluid outlet pressure	8,700 psi (600 bar)
Air motor diameter	3.25" (80 mm)
Air motor stroke	3.15" (80 mm)
Delivery at 80 cpm ⁽¹⁾	1.1 lb/min (500 kg/min)
Maximum free flow delivery	4.4 lb/min (2 kg/min)
Air inlet	3/8" NPT(F)
Fluid outlet	3/8" NPT(F)
Wetted materials	Cast Iron / Hard chromed steel / Steel / UHMWPE / NBR / PTFE / Viton®
Noise level	Pump noise level meets OSHA requirements at all recommended operating air pressures
Manual	853 827

(1) Delivery at 80 cycles per minute.

(2) Air consumption at 70 psi (5 bar) air pressure, NLGI-2 grease at 68 °F (20 °C) and 80 cpm.

ORDER INFORMATION

530 631	PM35 60:1 35 lb pail with bung adaptor
530 621	PM35 60:1 120 lb keg with bung adaptor
530 611	PM35 60:1 400 lb drum with bung adaptor

Hose Kit High pressure hose connection kit for PumpMaster 35 60:1



901

LP Hose 3/8" x 5'	813
HP Hose 3/8" x 5'	884
Quick Air Coupler 3/8" (F)	938F06
Quick Air Nipple 3/8" (M)	947M06
Swivel 3/8" (M/F)	1948

Drum Covers

	1934	35 lb Pail cover
	1936	120 lb Keg cover
	1938	400 lb Drum cover

Follower Plates

	962	35 lb Follower plate
	964	120 lb Follower plate
	966	400 lb Follower plate